



Instructions for Installation:
C10387 Half-Pipe Sconce

Lamping Specifications:
Integrated LED lamping:
Non-Dimming 120v thru 277v

6-OSRAM DE1 and 2-Sylvania HF2X modules

IMPORTANT! AT ALL TIMES WIRING TO BE DONE PER NATIONAL ELECTRIC CODES (NEC) OR APPLICABLE LOCAL CODES

**IMPORTANT | CAUTION
READ ALL INSTRUCTIONS THOROUGHLY.
TURN OFF POWER AT CIRCUIT BREAKER OR FUSE BOX BEFORE PROCEEDING.**



Figure 1

Step 1 Remove the fixture from packaging. Avoid using a sharp blade on the packaging, doing so may result in damage to the finish of lighting fixture.

Step 2 Locate the outlet box and with power off at circuit, route the power supply wires through the center of the universal mounting bracket and mount the universal bracket to the box using screws provided. (Figure 1)

Step 3 Make wire connections between the lighting fixture and the supply wires at the junction box. Connect the white fixture wire to the neutral supply wire; typically white. Connect the black fixture wire to the hot supply wire; typically black. Connect the fixture ground wire to the ground supply wire; typically copper or green.

Step 4 Carefully push the wire connections inside the outlet box, raise the fixture assembly and align the holes in the backplate with the threaded studs in the universal mounting bracket. (Figure 2)

Step 5 Secure the fixture backplate to the universal mounting bracket using the socket set screws located at the top and the bottom of the backplate. (Figure 3)

Step 6 Restore power at the breaker/fuse box and illuminate the lighting fixture.



Figure 2



Figure 3

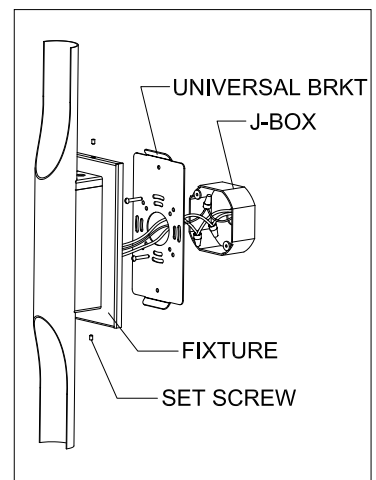

Figure 4