

Instructions for Installation:
C-10498 Optic Pendant

Lamping Specifications:
12v Integral Transformer

Incandescent: Halogen, One
MR16 "GU5.3 base" 50w max

LED GU5.3 base, 10.4w
(50w Halogen Equivalent)

**IMPORTANT! AT ALL TIMES WIRING
TO BE DONE PER NATIONAL ELECTRIC
CODES (NEC) OR APPLICABLE LOCAL
CODES**

**IMPORTANT | CAUTION
READ ALL INSTRUCTIONS THOROUGHLY.
TURN OFF POWER AT CIRCUIT BREAKER OR
FUSE BOX BEFORE PROCEEDING.**

Step 1 Remove fixture from packaging. Avoid using a sharp blade on the packaging, as doing so may result in damage to the fixture or finish.

Step 2 Turn off power to circuit at fuse box/circuit breaker.

Step 3 Attach the universal ceiling mounting bracket to the outlet box. (Figure 1)

Step 4 Carefully lift the fixture assembly up and attach the suspension bracket to the ceiling mounting bracket. Securely fasten into position with thumb nuts. (Figure 2)

Step 5 Make wire connections between the fixture and power supply wires. Connect the white fixture wire to the neutral supply wire; typically white, connect the black fixture wire to the hot supply wire; typically black, connect the copper fixture wire to the ground wire and/or the ground terminal in the outlet box. Push all connections inside of junction box. (Figure 3)

NOTE: This fixture can be dimmed using low voltage "reverse phase" or "trailing edge" dimming technology. If this fixture is installed on a circuit that will allow for dimming make sure that this fixture is controlled by an Electronic Low-Voltage (ELV) dimmer as opposed to a standard dimmer that is designed for use with magnetic ballast or incandescent lighting.

Electronic low-voltage dimmers are designed specifically for the special electrical requirements of electronic transformers. The electrical characteristics of an electronic transformer are capacitive (as opposed to an inductive magnetic transformer) and require special dimming considerations.

Step 6 Raise the canopy to the ceiling and align holes with threaded studs in the ceiling mounting plate. Secure the canopy against the ceiling with the center threaded accent piece. (See Figure 4)

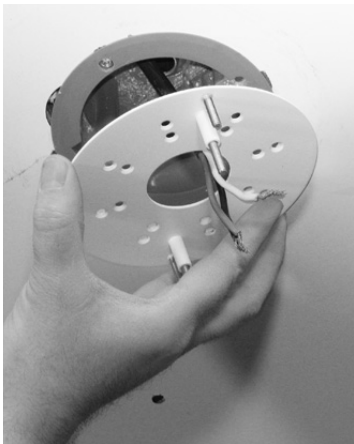

Figure 1



Figure 3

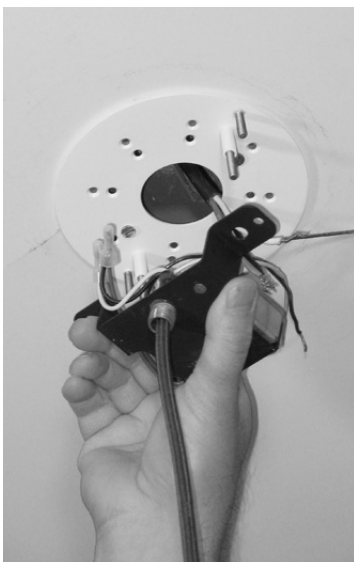

Figure 2



Figure 4

BOYD

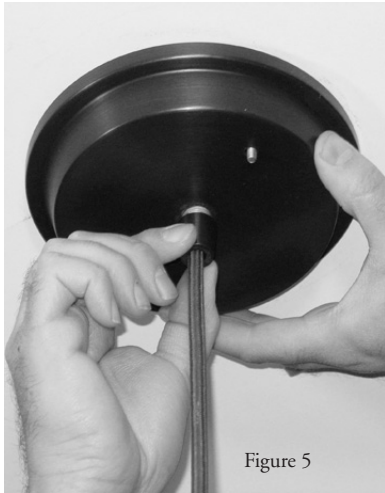

Figure 5

Step 7 Install decorative knobs onto the threaded studs and secure against the canopy. (See Figure 5)

Step 8 Carefully install the glass lens into the lower portion of the fixture. Orient the glass lens so that it will nest into the bottom decorative ring.

Step 9 Secure the glass lens into fixture ring with brackets and screw hardware provided with the fixture. (See Figure 7)

Step 10 Restore power to the circuit and illuminate the fixture.



Figure 6

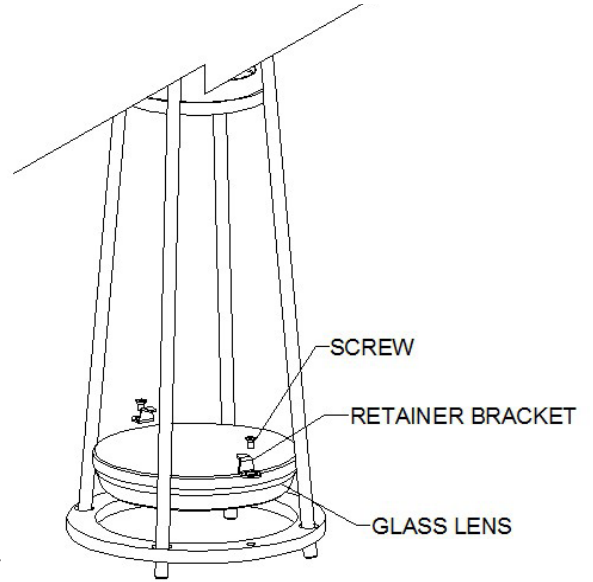

Figure 7

Special Considerations:

This fixture has been shipped from the factory with a 12v LED lamp that uses only 10.4 watts. This LED is equivalent to a 50w halogen but runs much cooler and more efficiently with an estimated lamp life of 35,000 hrs and a 3 year warranty.

Note: This fixture can also be lamped with a halogen MR-16 (GU5.3 base) lamp 50w max.